

Internal valves

F614 4-inch valve, F620 6-inch valve



01 Internal valves F614 4-inch valve, F620 6-inch valve

The Meggitt bottom loading system designed for aircraft refuelers utilizes the unique jet level sensor in conjunction with an internal valve. This system combines automatic bottom loading with off-loading (aircraft refueling) through one valve. Available in 4-inch and 6-inch sizes, the internal valves are built with modular pilots to allow the use of the internal valve as a standard off-loading valve only with easy conversion to bottom loading at a later date.

Operating description

Inlet pressure transmitted thru jet level sensor opens pilot thus allowing main valve to open as determined by system flow capacity.

When the level in the compartment reaches the jet level sensor, the pilot pressure drops off and the pilot spring closes the pilot causing the main piston to close due to its area overbalance.

Air pressure (50 to 150 psi) applied to power piston lifts main piston to full open position.

When air pressure is released large spring closes main piston.

02 Key Features

- No moving parts in high level control
- 4-inch internal valve mates NTT standard flange-removable from outside. 6-inch valve furnished with steel welding ring (mounting does not mate with NTT flange). Stainless steel ring optional
- Soft closure feature for surge control
- Loading and off-loading through one valve
- Fail closed system
- Lightweight design
- Air operation for off-loading
- Modular pilot construction for ease of maintenance.
- Low pressure loss:
 - Bottom Loading
 - 4-inch - 4.5 psi at 600 gpm
 - 6-inch - 4.5 psi at 1200 gpm
 - Off-Loading
 - 4-inch - 1.5 psi at 600 gpm
 - 6-inch - 0.75 psi at 1000 gpm
- Functions properly with inlet pressures to 200 psi
- Internal valves can also be used with F619 three-way float pilot valve

Internal valves F614 4-inch valve, F620 6-inch valve

03 Key Dimensions

* MOUNTING HINT: USE FLEXIBLE TUBING FOR PILOT AND AIR LINES OF SUFFICIENT LENGTH TO ALLOW REMOVAL OF VALVE FROM THE EXTERIOR OF THE VEHICLE.

F614 MAY BE MOUNTED FROM INSIDE OR OUTSIDE OF SUMP FLANGE

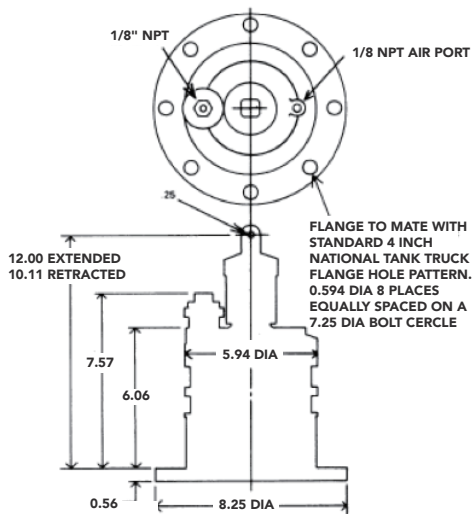

F614 MOUNTING DIMENSIONS

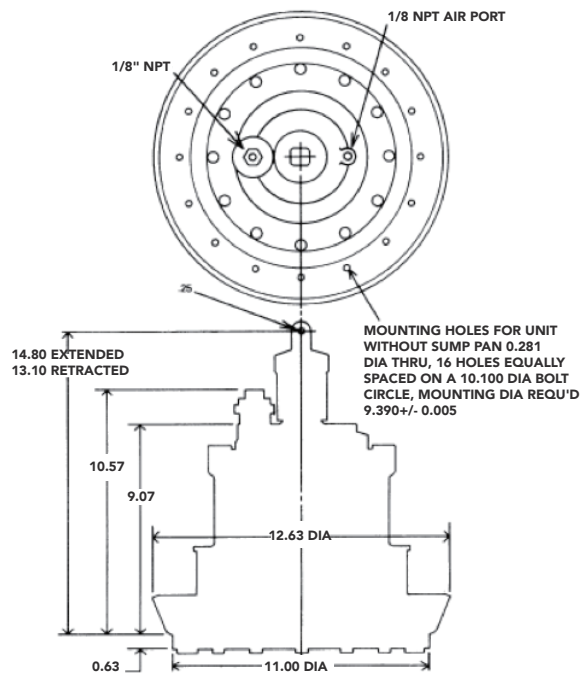

F620 MOUNTING DIMENSIONS

04 Contact

Meggitt Shanghai Office

Address: Rm1107, Block A, No.319 XianXia Road, Changning District
Shanghai, China

Telephone: +86 21 6278 1096

Website: <https://www.meggitt.com/products-services/ground-fuelling>

Meggitt (Xiamen) Sensors & Control Co., Ltd.

Address: No. 230 South 5 Gaoqi Road, Xiamen 361006,
P.R. China

Telephone: +86 592 5733 666

Website: www.meggittxiamen.com/gfp